



290 Baig Blvd. Suite B1
 Moncton, New Brunswick
 E1E 1C8
 Canada
 Bus:(506) 863-0300
 Fax:(506) 863-0330
 www.motionfab.com
 info@motionfab.com



System Overview

Ultralab 60 is equipment developed for automating the lens manufacturing process for the ophthalmic industry. A particular system, UL60, is a complex integrated automation system which allows one operator to produce lenses through the blocking, cutting, polishing and coating process.

Key features and Technologies used are:

- 18 axis of servo motion with 3 coordinate systems up to 5 axis
- 20+ pneumatic actuations.
- Two control systems; one for factory interfacing, HMI, mathematical computations and SCADA; the other for motion control and real-time PLC database of 5000+ variables.
- Distributed System with Ethernet and prefabs fieldbus with 20+ nodes.
- Live video imaging system
- UV light/compound dispensing and curing system
- Barcode & RFID Identification
- Automatic Tool Changer
- Waste Management

Technical Services

MotionFab provides onsite services with equipment locate in Japan, California, Dallas, and Ohio.

Our service technicians provides:

- phone support
- onsite trouble shooting
- part replacement,
- part refurbishment,
- software & PLC upgrades
- system productivity enhancements
- preventative maintenance
- internal customer training
- Part Stocking of critical & wearable components

Your automation needs?

Inquire with MotionFab about your plant or system automation needs. MotionFab provides full turn-key solutions as well as after installation support.

Email info@motionfab.com with details or call directly.

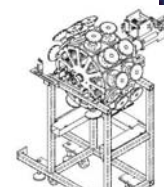
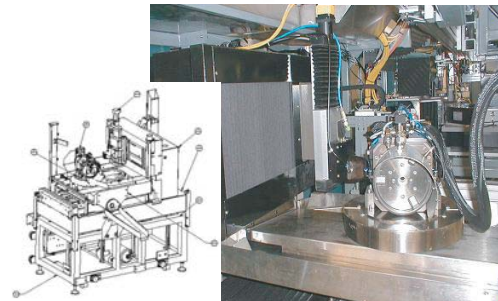
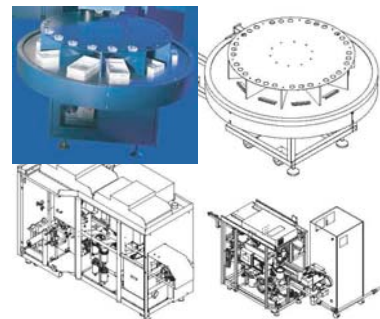
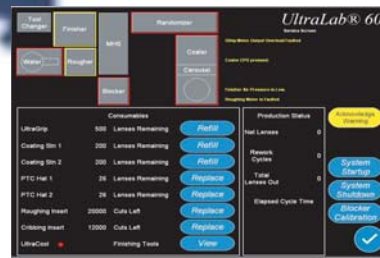

Advanced Automation

Equipment Services